

Combo DB15 LCD Console Drawers – Large Screen (pivot)

Optimize rack space. Maximize rack monitoring



Optional Remote IP Access

- An expansion slot allows you to add an optional KVM over IP module to enable remote access to your servers.
- Gain BIOS level access to your servers for system maintenance, support or failure recovery via secure SSL authentication and encryption.



LCD console drawer provides a variety of features that simplify to access servers to making system monitoring, troubleshooting and software upgrades.

The self-locking rails when in the fully extended open position and the ultra convenient auto lock release when the LCD panel is closed, make for simple and hassle free operation.

Configure with 21.5 or 23.8 inch A-Grade FHD LCD panels, combo DB15 single, 8 or 16 port integrated KVM switch & with an option remote IP console.

Features

- Facilitated by screen rotate function.
- Support combo interface, GA-USB & VGA-PS/2.
- Durable 104-key keyboard and touch pad.
- Quick and simple installation.
- Self-locking and auto release rails for ultra convenience.
- Port selection via push buttons or On-Screen-Display (OSD).
- Dedicated daisy chain port to expand up to 240 servers.
- Access Control List (ACL) security function for up to 8 independent user accounts.



Rear of KVM-2101AST-M5
Rear of KVM-2401AST-M5



Rear of KVM-2108AST-M5
Rear of KVM-2408AST-M5

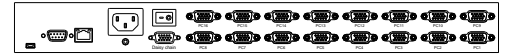

Rear of KVM-2116AST-M5
Rear of KVM-2416AST-M5

Part No.	KVM-2101AST-M5	KVM-2108AST-M5	KVM-2116AST-M5	KVM-2401AST-M5	KVM-2408AST-M5	KVM-2416AST-M5
Direct no. of Computers	1	8	16	1	8	16
Maximum no. of Computers	1	232(Daisy Chain)	240(Daisy chain)	1	232(Daisy Chain)	240(Daisy chain)
LCD	Size	21.5"		23.8"		
	Backlight	LED		LED		
	Resolution	1920*1080 FULL HD (support up to 1920*1200)		1920*1080 FULL HD (support up to 1920*1200)		
	Max.color	16.7M		16.7M		
	Luminance	250cd/m2		250cd/m2		
	View Angel (H/V)	178 / 178		178 / 178		
	Contrast Ratio	3000 : 1		1000 : 1		
Port Selection	N/A	Push Button, OSD or Hotkey		N/A	Push Button, OSD or Hotkey	
Expansion Slot	N/A	Yes, option for Remote IP Access		N/A	Yes, option for Remote IP Access	
KB/Mouse Emulation	USB & PS2					
Rack Depth	600mm to 1300mm (rack cabinet front rails to rear rails)					
Power	100-240V AC 50/60Hz via IEC Type power cord					
Environment	Operation temp: 0 to 50℃ Storage temp: -20 to 60℃ Humidity: 10% - 90%, non-condensing Shock: 10G acceleration (11ms duration) Vibration: 17 to 500Hz 1G PTP					
Physical Dimensions / Net Weights	448 x 44 x 790mm (WxHxD) / 19.5KG					
Packing Dimensions / Gross weights	580 x 195 x 940mm (WxHxD) / 23KG					
Accessory						
1.8meter IEC Type Power Cord (1.8meter VGA& PS2Cable + 1.8meter USB A Type Cable for KVM-2401AST-M5)						
Option Relate Item						
CVU-018	1.8meter 2-in-1 KVM Cable-USB&VGA		CVP-018	1.8meter 3-in-1 KVM Cable-PS/2&VGA		
CVU-030	3.0meter 2-in-1 KVM Cable-USB&VGA		CVP-030	3.0meter 3-in-1 KVM Cable-PS/2&VGA		
CVU-050	5.0meter 2-in-1 KVM Cable-USB&VGA		CVP-050	5.0meter 3-in-1 KVM Cable-PS/2&VGA		
DIP-101	KVM over IP module for Remote Bios Level Access					

Specifications subject to change without notice

USA (Head Quarter)
Denichi Computer Devices, Inc.
13200 Pond Springs Rd. #A102, Austin, TX 78729
Office: 512-837-2655
Fax: 512-837-1694
Email: sales@denichi.com

China (Factory)
Add : The south faces industry area of Xia Gang Fu Hai road, Chang'an Town, Dongguan City, Guangdong, China
Email: sales@denichi.com

Combo DB15 LCD Console Drawers – Large Screen (pivot)

Optimize rack space. Maximize rack monitoring



Lift the display



Display rotate to the right



Operating position

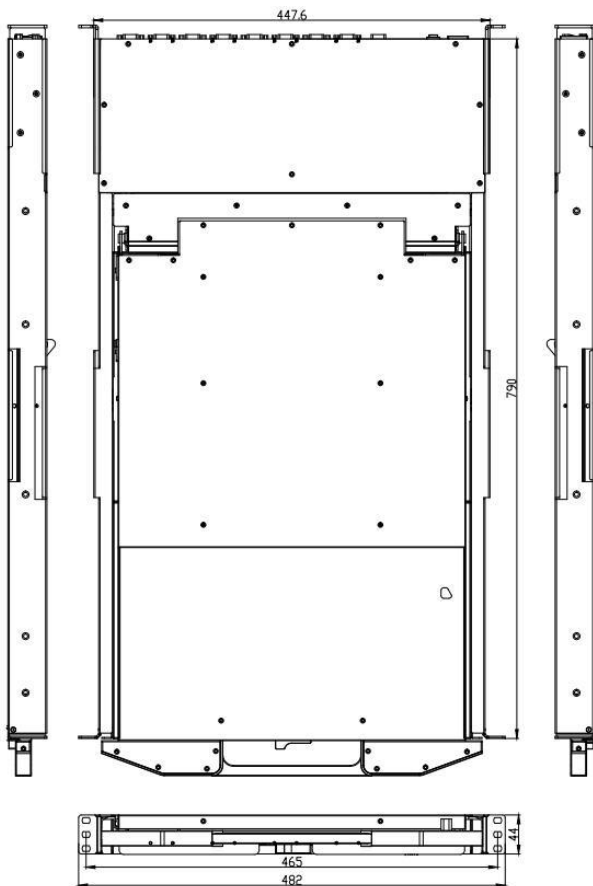

Rear of KVM-2101AST-M5
Rear of KVM-2401AST-M5



Rear of KVM-2108AST-M5
Rear of KVM-2408AST-M5

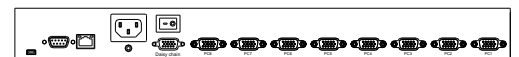

Rear of KVM-2116AST-M5
Rear of KVM-2416AST-M5

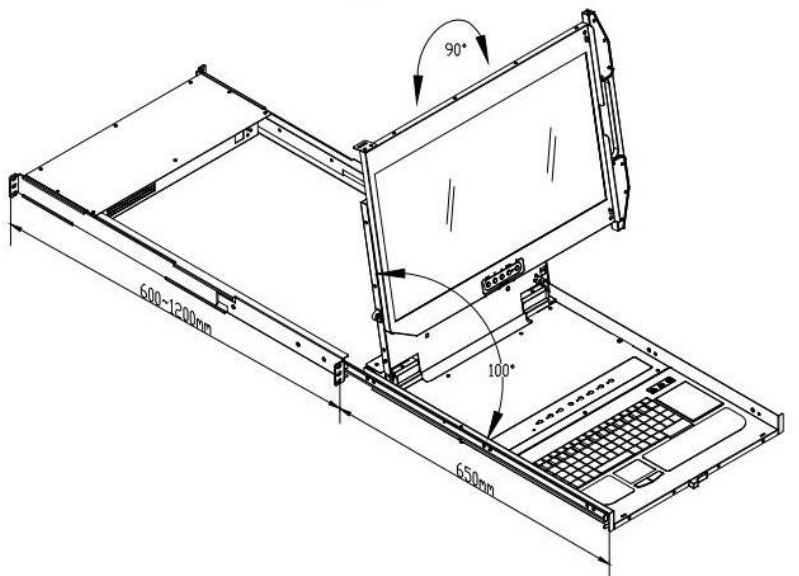
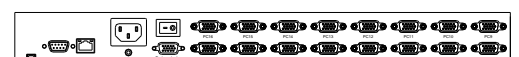

USA (Head Quarter)
Denichi Computer Devices, Inc.
13200 Pond Springs Rd. #A102, Austin, TX 78729
Office: 512-837-2655
Fax: 512-837-1694
Email: sales@denichi.com

China (Factory)
Add : The south faces industry area of Xia Gang Fu Hai road, Chang'an Town, Dongguan City, Guangdong, China
Email: sales@denichi.com